



**MED MODEL OVS**



**Mueller  
Environmental  
Designs, Inc.**



**Air Filtration  
Evaporative Cooling  
Noise Control  
Mist Elimination  
Turnkey Projects**



# MED Model OVS

## APPLICATION

The Model OVS is designed as a “source control” for entrained hydraulic and lubricating fluids venting to atmosphere from the exhaust gas port of Shafer, EIM and similar valve operators.

## PRINCIPLE OF OPERATION

The Valve Operator Vent Mist Extractor Model OVS will remove 99% of all entrained liquid particles 10 microns and larger from the venting gas.

## PERFORMANCE

Gas vapor and entrained fluids enter the Valve Operator Vent Mist Extractor through the inlet nozzle, contacting the separating element. The separating element surfaces act as an agglomerator, setting up centrifugal forces, throwing liquid particles to the shell wall in a sheeting action. The coalesced liquid particles then drain into a holding area for collection to a central sump. A vortex breaker prevents re-entrainment of the liquid as gas exits the OVS. The unit is designed for a vertical down discharge.

## OPTIONS

- Support Clamps
- Multiple Unit Collection Sump
- 304 SS Construction
- Insect Barrier

## FEATURES

- High Separating Efficiency
- Self Cleaning
- No Moving Parts
- Low Maintenance Requirements
- Simple Installation
- No Replacement Elements



*Gas Motor Operated Valve Operator With Vent Mist Extractor Removes 99.8% All Entrained Liquids 6 Microns and Larger.*



*Gas Motor Operator Without Vent Mist Extractor*

## WARRANTY

Mueller Environmental Designs, Inc. warranties against poor workmanship, material defects and failure due to improper equipment selection.

# Typical Configurations

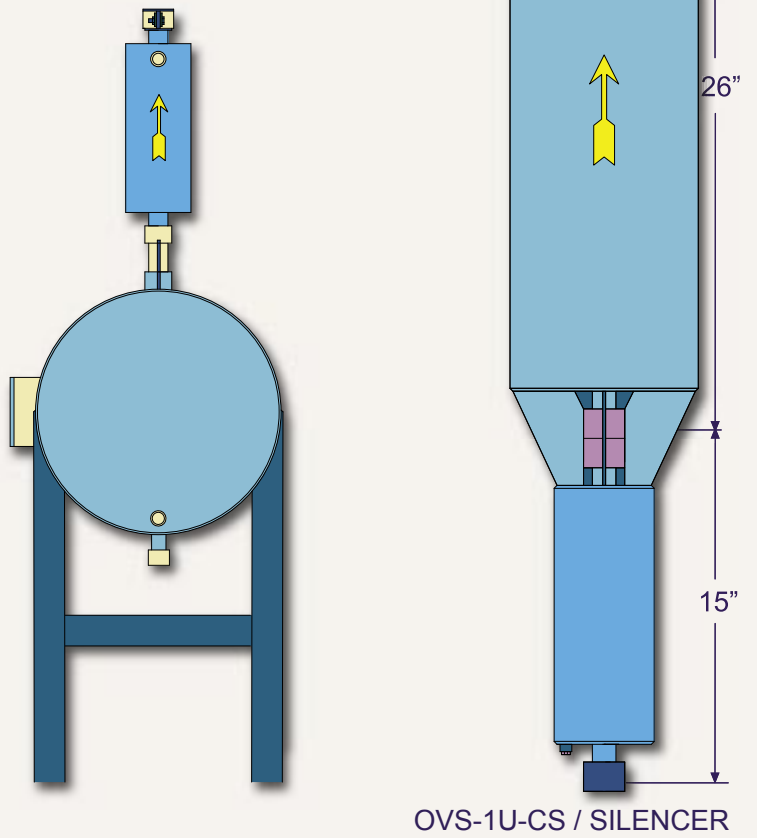
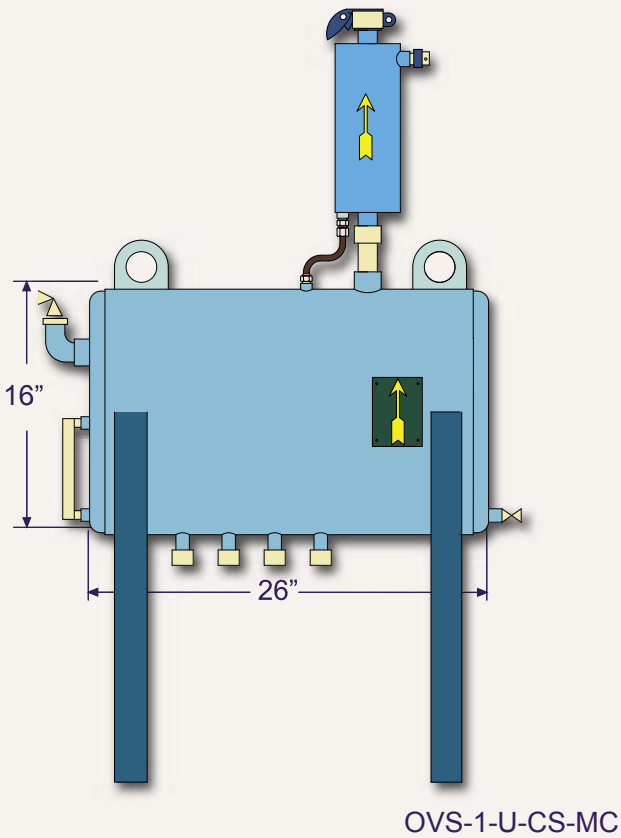
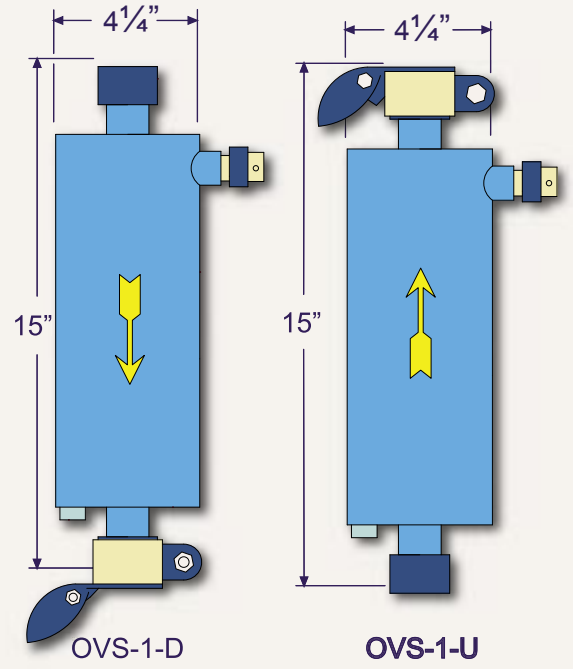
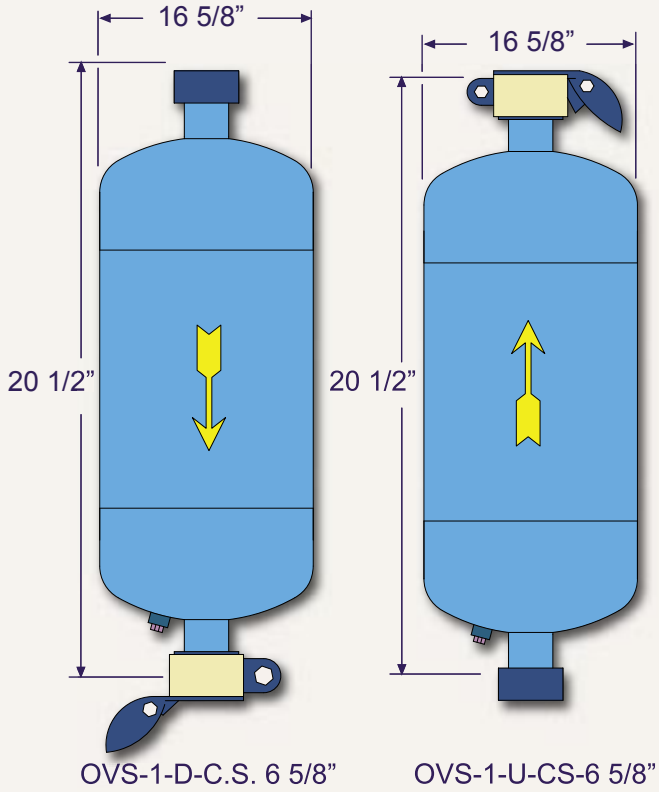



*Gas Over Hydraulic Valve Actuator Vent Mist Extractor Removes 99.98% All Entrained Liquids 6 Microns and Larger*



*Multi-Connection Gas Over Hydraulic Valve Actuator -15 Gallon Sump*



*Gas Motor Operated Valve With Operator Vent Mist Extractor/Silencer Removes 99.8% All Entrained Liquids 6 Microns and Larger and Reduces Vent Noise to 85 Dba at 3 Feet*



*Gas Motor Operated Valve Operator With Vent Mist Extractor Removes 99.8% All Entrained Liquids 6 Microns and Larger With One Gallon Liquid Holding Sump*

## **Mueller Environmental Designs, Inc.**

7607 Wright Road

Houston, Texas 77041

713-465-0995

Fax 713-465-0997

E-Mail: [sales@muellerenvironmental.com](mailto:sales@muellerenvironmental.com)

[www.muellerenvironmental.com](http://www.muellerenvironmental.com)